



BAUER

FOR A GREEN WORLD



HELIXDRIVE

**The Eccentric Screw Pumps for
media with low and high viscosity**

The Eccentric Screw Pumps with exceptional performance

Permanently lubricated cardan joints beneath wearfree, highly tear-resistant Elastopal sleeves

Driveshaft with oil bath bearing and mechanical seal

Abrasion-resistant, hardened low friction hollow rotor made of tough tool steel

Frost-proof and break-proof housing made of hot dip galvanised steel

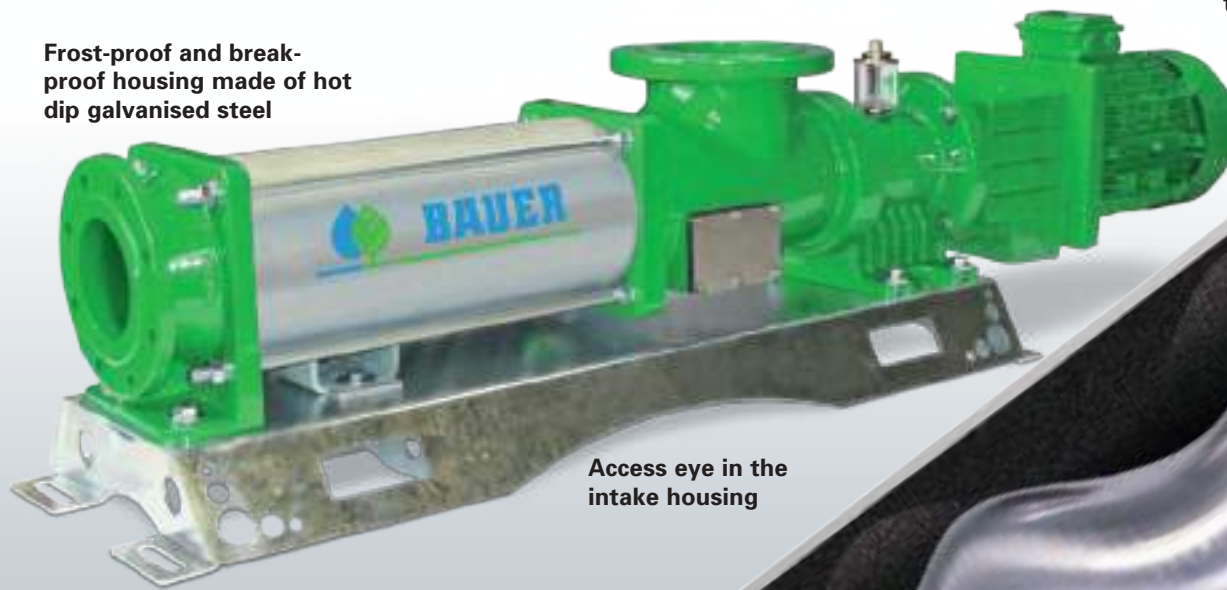

Access eye in the intake housing

Non-swelling stator made of special rubber compound

Unique rotor

The low friction hollow rotor – the key component of every eccentric screw pump – is manufactured in a unique special process in the BAUER factory and is absolutely break-proof.

Longer durability

Tough tool steel and a consistent wall thickness of 8 mm prevent heat accumulation and stress cracks. The special coating applied makes for a tough and smooth surface.

This process also ensures a longer life of the stator rubber, as the smooth rotor surface causes considerably less abrasion.

Exceptional smoothness

The light weight of the low friction hollow rotor guarantees consistent running smoothness in all speed ranges.

For media with low and high viscosity:

- Thick slurry
- Liquid manure
- Sewage sludge
- Bog
- Spent grains
- Draff
- Molasses
- Potato pulp
- Starch
- etc.





BAUER

FOR A GREEN WORLD

Eccentric screw pump with motor drive – ideal for stationary use in both agricultural and industrial applications.

Use:

- intertank transfer
- dosing
- feeding
- flushing
- bringing in

Characteristics:

- Abrasion resistant, hardened smooth-running cupped rotors made of tough toolsteel – manufactured by BAUER with a special technology and absolutely break-proof
- thermally optimatated bearing for continuous operation
- mechanical seal running in oil bath
- large dimensioned intake and pressure connections to reduce plugging
- access eye in intake housing
- robust, permanently lubricated cardan joints
- compact form of structure
- chassis for quick and safe mounting
- lockable drive for easy change of rotor and stator
- quiet running
- easy to maintain
- self priming

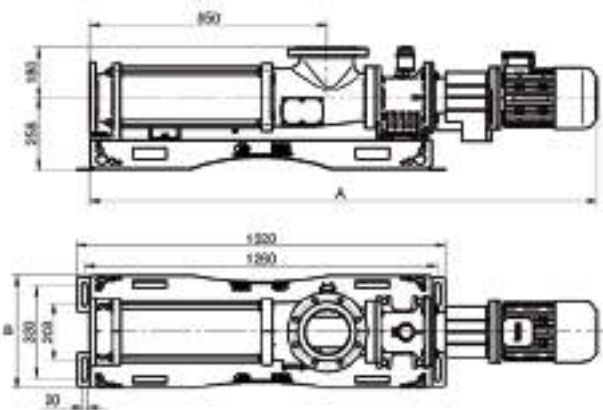

HELIX Eccentric Screw Pumps



High quality and reliability

In House factory production guarantees both reliable and immediate availability of consistently high-quality spare parts.

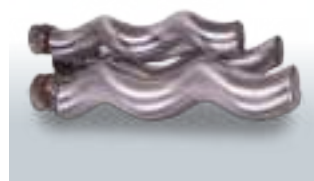

Extensive accessories such as:

- Stone catcher in form of a box or can
- Aspiration mouth with integrated stone catcher
- Drum filling station with adjustable discharge pipe
- All components for suction and pressure lines

Technical Data

| Pump type | HELIXDRIVE 553 | HELIXDRIVE 556 | HELIXDRIVE 753 | HELIXDRIVE 756 | HELIXDRIVE 1103 | HELIXDRIVE 1106 |
|----------------------------------|----------------|----------------|----------------|----------------|-----------------|-----------------|
| Performance kW | 5.5 | 5.5 | 7.5 | 7.5 | 11 | 11 |
| Flow high max. m | 30 | 60 | 30 | 60 | 30 | 60 |
| Flow rate max. m ³ /h | 38 | 15 | 48 | 18 | 65 | 35 |
| Flange suction side DN | 150 | 150 | 150 | 150 | 150 | 150 |
| Flange pressure side DN | 125 | 125 | 125 | 125 | 125 | 125 |
| Dimensions mm A x B | 1850 x 400 | 1745 x 400 | 1873 x 400 | 1850 x 400 | 1868 x 400 | 1950 x 400 |

Rated power with water



BAUER

FOR A GREEN WORLD

HELIXDRIVE Eccentric Screw Pumps are multifunctional

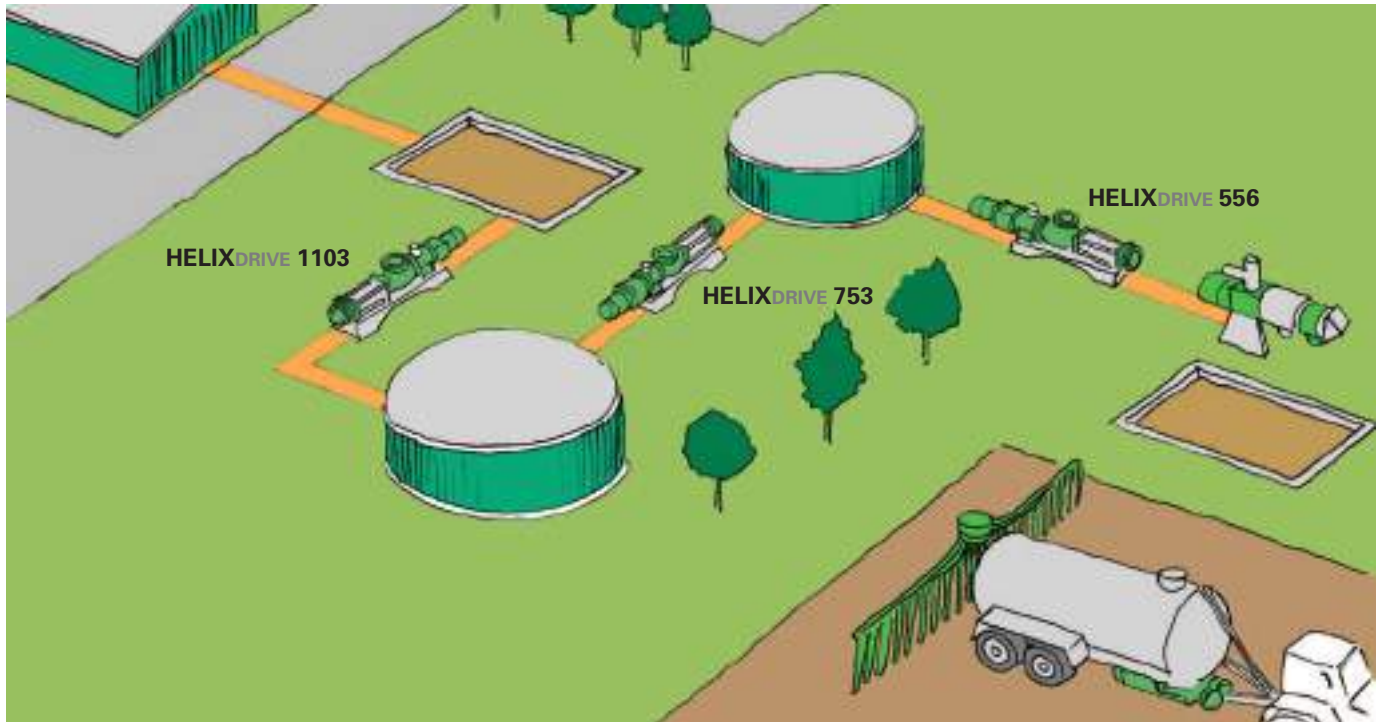

Your Dealer:



Calle 132 # 50 - 45
Tel: (+57)(1) 626 1955 · 626 2797
www.comercialderiegos.com
info@comercialderiegos.com
Bogotá, Colombia

Röhren- und Pumpenwerk BAUER Ges.m.b.H.
8570 Voitsberg, Austria
Tel. +43 3142 200-0
Fax +43 3142 200-320 / -340
sales@bauer-at.com
www.bauer-at.com

A BAUER Group company

